

Install for M10 stylr with 3/4" ID holes in steel

1. Find location where board will be installed and with 2 people place steel panel against wall and with a level make sure its level. With a pencil use w countersunk holes to outline anchor location on wall.

2. Inserts wall anchors in exact center of circles you drew use #2 .221" drill bit or a 7/32 .2188"

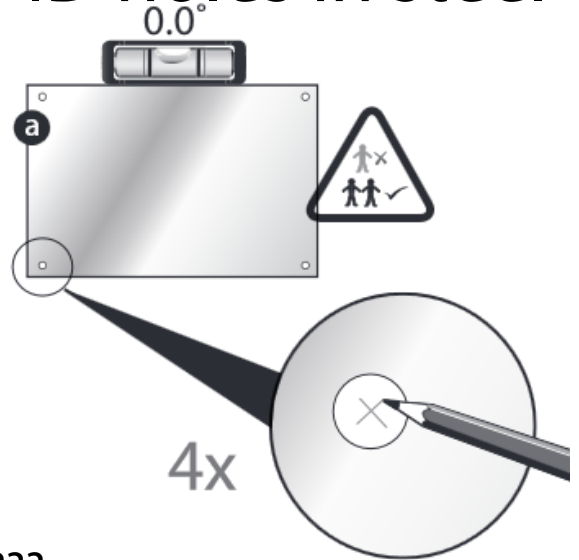

Questions????

Call 860-632-2026 x111 for help

3. Mount standoffs into wall anchors

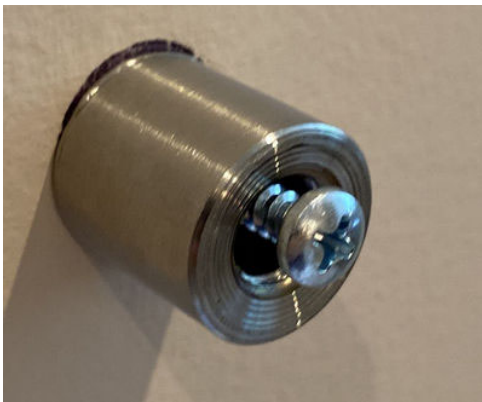

4. 4 standoffs in corners and one in center for total of 5.

Note Center standoff is shorter and uses its cap to support center. 4 corners loses caps

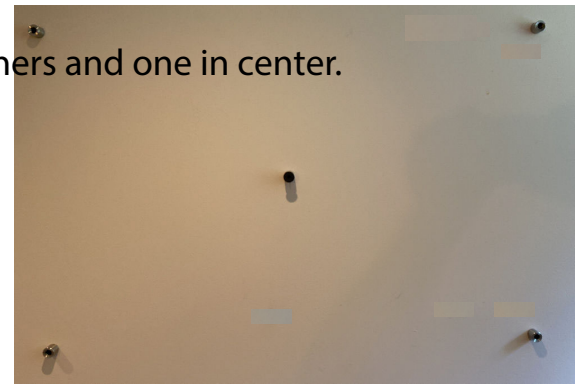

5. Center standoff also takes a flathead set to height so that it is slightly more than height of standoff and spacer. This keeps the board from bowing

6. With 2 people mount steel to wall with countersunk spacer between standoff and steel. The 10 mm countersunk flathead bolt uses a 6 mm hex wrench



<==. Mounted steel ready for overlays. Insert and lens cover or filmed overlay