

MODEL 196LS LINE SHAFT DRIVEN LIVE ROLLER

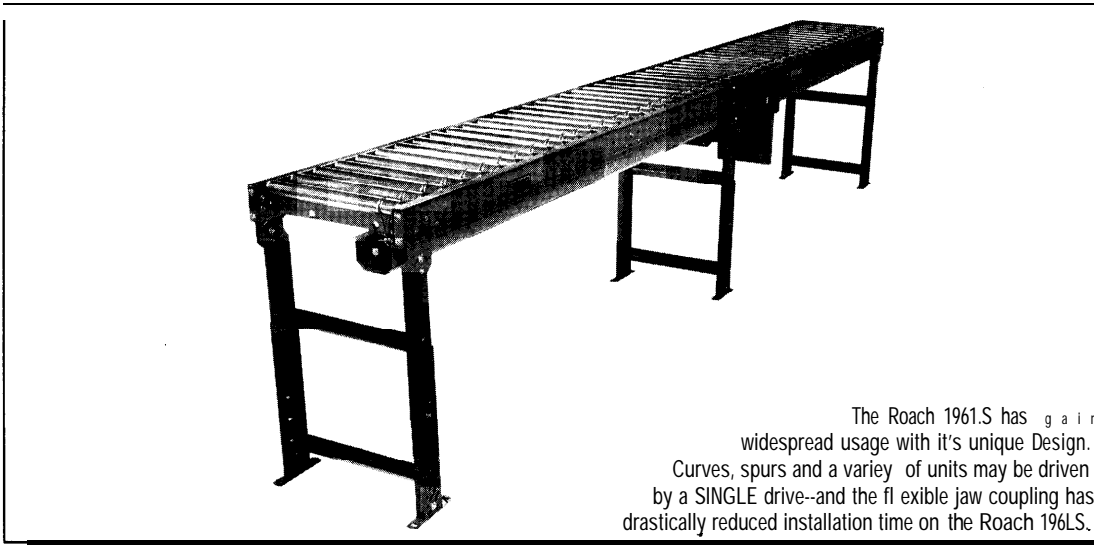

The Roach 196LS has gained widespread usage with its unique Design. Curves, spurs and a variety of units may be driven by a SINGLE drive--and the flexible jaw coupling has drastically reduced installation time on the Roach 196LS.

SPECIFICATIONS

TREAD ROLLERS: 1.9" dia. x 16 ga.

DRIVE BELT: 3/16" dia., polyurethane belts. Nominal 15 lbs. per roller drive.

DRIVE SHAFT: 1" dia.; CI 018 cold rolled steel shaft.

COUPLINGS: Flexible jaw coupling with shock absorbing Hytrel insert, located both ends, or one end only (specify).

CENTER DRIVE: Reversible drive; located approximately 24" from end of bed section.

BEARINGS: Precision, lubricated, ball bearing units with steel housings.

SPEED: 60 FPM, constant.

BED: 4-1/2" x 1-1/2" x 10 ga. formed steel channel frame. Bed sections attached with couplings and floor supports.

FLOOR SUPPORTS: Adjustable 29" to 41" TOR. Supports can be lagged to floor.

MOTOR DRIVE: 1/3 HP, 230/460/3, 60 cycle, ODP right angle gear motor.

ROLLER CHAIN: Drive shaft is driven by No. 50 chain. Chain take-up provided on motor base.

CAPACITY: See page 5 in technical section for load capacity rating.

ELECTRICAL CONTROLS: Available as an option.



Indoff Distributor 860-632-2026

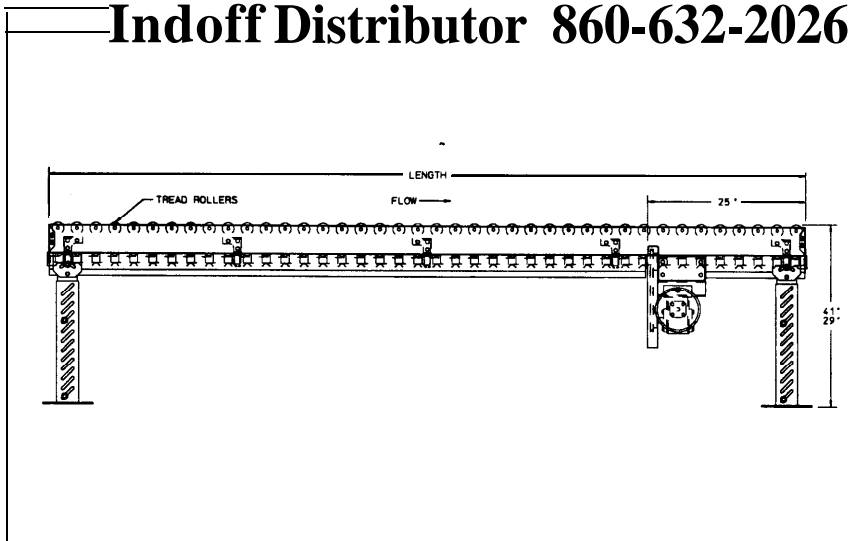

HP @ 60FPM	REDUCER	"A"
1/3, 1/2	RDW1 1100-02	24"
3/4, 1	RDW1 1100-02	24"
1-1/2, 2	RDW1 1100-04	25-1/4"

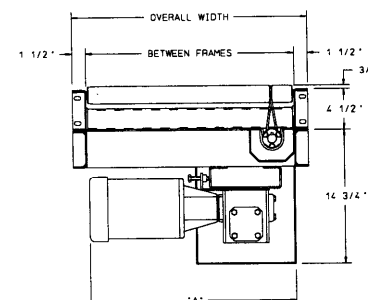

SPECIFICATION TABLE

CONVEYOR	LENGTH	2'	5'	10'	15'	20'	25'	30'	40'	50'	60'	70'	80'	90'	100'
BF	OAW	Unit weights (lbs.) with 3" roller centers (For other centers, deduct weights below)													
15"	18"	223	301	433	537	697	801	961	1225	1489	1753	2017	2281	2545	2809
19"	22"	234	321	465	609	753	897	1041	1329	1617	1905	2193	2481	2769	3057
21"	24"	247	340	485	640	795	988	1105	1415	1725	2035	2345	2655	2965	3275
25"	28"	253	358	513	678	833	993	1153	1473	1793	2113	2433	2753	3073	3393
27"	30"	258	369	535	701	867	1033	1199	1531	1863	2195	2527	2859	3191	3523
33"	36"	267	396	578	760	942	1124	1306	1670	2034	2398	2762	3126	3490	3854
39"	42"	286	433	633	833	1033	1233	1433	1833	2233	2633	3033	3433	3833	4233

Deduct the following weights (lbs.) for other than 3" centers

TREAD ROLLER CENTERS	15" BF		19" BF		21" BF		25" BF		27" BF		33" BF		39" BF	
	Per 5'	Per 10'	Per 5'	Per 10'	Per 5'	Per 10'	Per 5'	Per 10'	Per 5'	Per 10'	Per 5'	Per 10'	Per 5'	Per 10'
4"	-14	-28	-17	-34	-19	-37	-21	-42	-23	-45	-27	-53	-31	-62
6"	-28	-56	-34	-68	-37	-74	-42	-84	-45	-90	-53	-106	-62	-124

OPTIONAL EQUIPMENT

SIDE MOUNTED DRIVE: With 10' minimum elevation.

GUARD RAILS: Adjustable channel or solid formed steel.

FLOOR SUPPORTS: Other height supports available, adjustable or fixed. Castered supports also available.

CEILING HANGERS: 5/8" dia. threaded rod with hardware to attach rods to conveyor. Provides 6' clearance between ceiling and TOR (furnished in place of floor supports).

CONVEYOR SPEED: Constant speed; 30-120 FPM (specify). Other constant or variable speeds available. **NOTE: CAPACITY CHANGES WITH SPEED.**

MOTORS: Available through 2 HP with characteristics such as totally enclosed, single phase, etc.

ELECTRICAL CONTROLS: Manual start/stop push button switch; reversing drum switch; magnetic starter (one direction or reversible); limit switch; photo relay; others available.

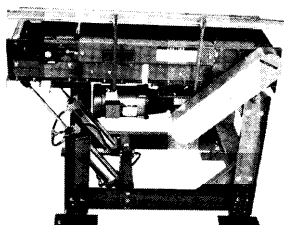

A Roach 350BSB Slider Bed Belt Conveyor (see pg. 12-13)-modified to accept goods from two levels via double action air cylinders.

JAW COUPLING

